

NIROH®



Piet Coffee Table
by Rohdesign Studio

Piet Coffee Table

by Rohdesign Studio

Die Gestaltung des Piet Coffee Tables gründet auf traditionellen Handwerkstechniken – neu interpretiert. Handgedrechselte Module aus Massivholz zieren die Tischsäule. Je nach Bedarf können die Module abgenommen werden – so bleibt der Tisch wandelbar.

EINFACH UND WANDELBAR, MINIMALISTISCH UND DOCH VERSPIELT.



PRODUCT OPTIONS

TABLE TOP



STEEL BLUE POWDER COATED

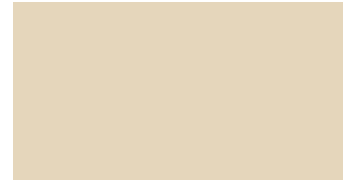

STEEL CREME POWDER COATED

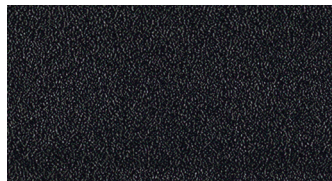

STEEL BLACK POWDER COATED



STEEL CORAL POWDER COATED



LEACHED AND SOAPED SPRUCE



SOAPED OAK

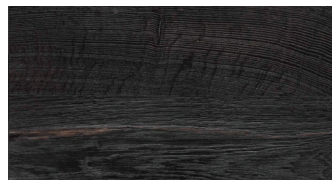

BLACK BURNED+ OILED OAK

MODULES

LEACHED AND SOAPED SPRUCE
SOAPED OAK
BLACK BURNED+ OILED OAK

BASE

POWDER COATED BLUE
POWDER COATED CREME
POWDER COATED BLACK
POWDER COATED CORAL

Piet Coffee Table

by Rohdesign Studio

TECHNICAL SPECIFICATIONS

PRODUCT TYPE

Coffee Table

MATERIALS

Oak or Spruce, Steel

PACKAGING TYPE

Brown box

ENVIRONMENT

Indoor

WEIGHT ²⁾

Base
3250g

Spruce tabletop
ø 450mm: 3000g

Oak tabletop
ø 450mm: 4000g

Steel tabletop
ø 450mm: 5000g

Modules
Module package spruce: 3000g
Module package oak: 4000g

COLOUR

Tabletop
Powder coated blue
Powder coated creme
Powder coated black
Powder coated coral
Oak soaped
Black burned Oak
Spruce leached and soaped

Base
Powder coated blue
Powder coated creme
Powder coated black
Powder coated coral

Modules
Spruce leached and soaped
Oak soaped
Black burned Oak

DIMENSIONS ¹⁾

H: 390 | 420mm
(Stahl- | Holztischplatten)

MATERIALS & MAINTENANCE

Please visit niroh.de for materials and care and maintenance instructions.

All our products are made from natural materials according to traditional craftsmanship. We ask for your understanding that there may be dimensional deviations may occur - if the deviation is within the specified tolerance, this is not a reason for complaint.

1)Tolerance: +/- 15mm

2)Tolerance: +/- 15%

Piet Coffee Table

by Rohdesign Studio

TECHNICAL DRAWING

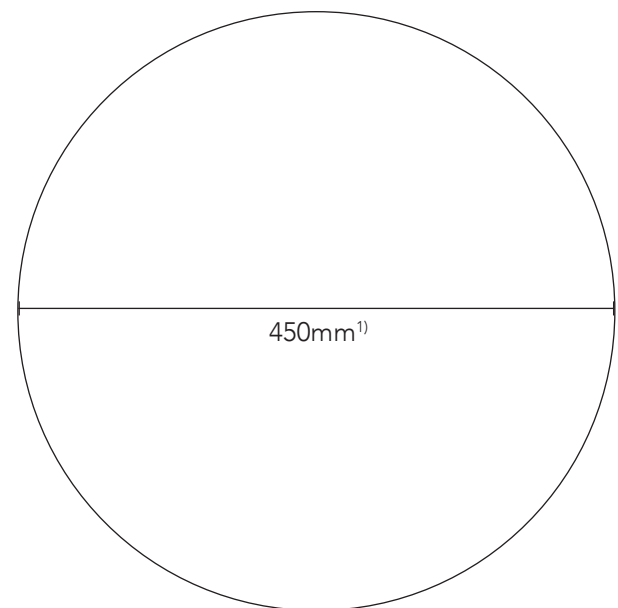
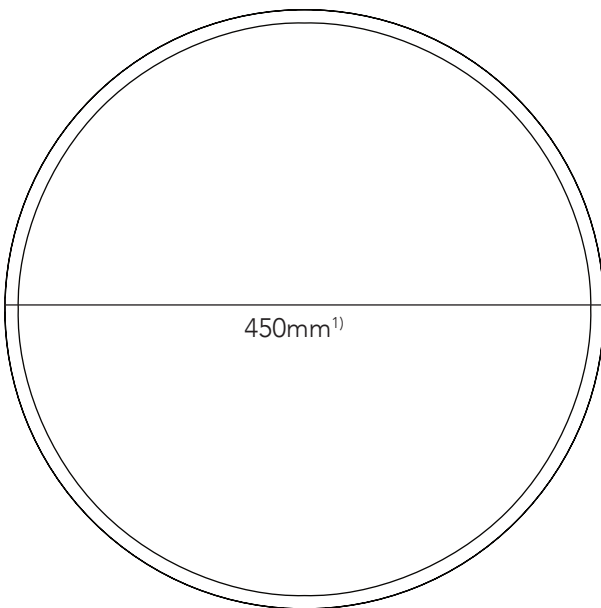
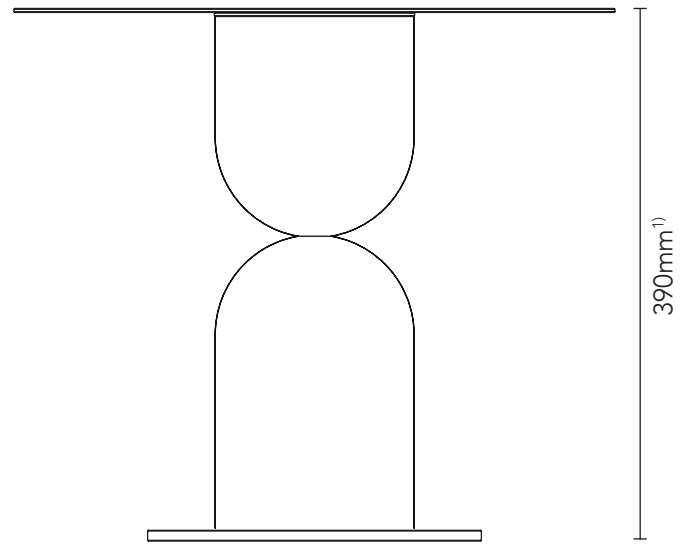
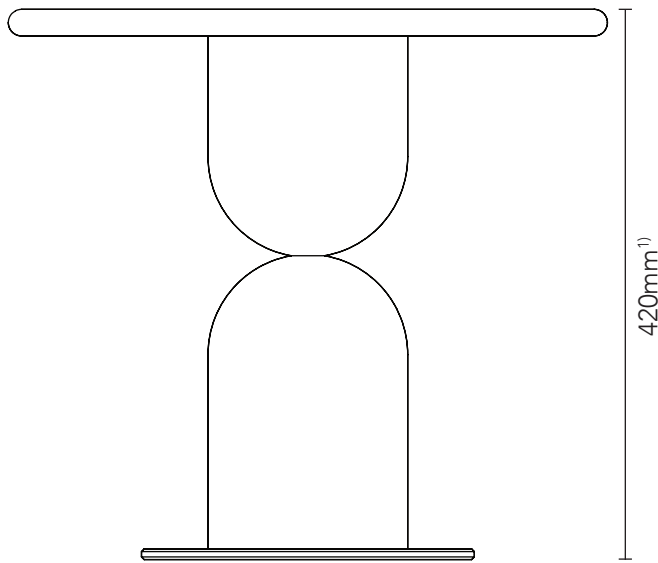

All our products are made from natural materials according to traditional craftsmanship. We ask for your understanding that there may be dimensional deviations may occur - if the deviation is within the specified tolerance, this is not a reason for complaint.

1)Tolerance: +/- 15mm